

AutoMax[®] Power Supply Modules and Racks

M/N 57C493 Power Supply Module

M/N 57C494 Power Supply Module

M/N 57C331 16-Slot Rack

M/N 57C332 10-Slot Rack

M/N 57C334 6-Slot Rack

Instruction Manual J2-3008-4

**Rockwell
Automation**

DANGER

ONLY QUALIFIED ELECTRICAL PERSONNEL FAMILIAR WITH THE CONSTRUCTION AND OPERATION OF THIS EQUIPMENT AND THE HAZARDS INVOLVED SHOULD INSTALL, ADJUST, OPERATE, OR SERVICE THIS EQUIPMENT. READ AND UNDERSTAND THIS MANUAL AND OTHER APPLICABLE MANUALS IN THEIR ENTIRETY BEFORE PROCEEDING. FAILURE TO OBSERVE THIS PRECAUTION COULD RESULT IN SEVERE BODILY INJURY OR LOSS OF LIFE.

DANGER

THE USER IS RESPONSIBLE FOR CONFORMING WITH ALL APPLICABLE LOCAL, NATIONAL, AND INTERNATIONAL CODES. WIRING PRACTICES, GROUNDING, DISCONNECTS, AND OVER-CURRENT PROTECTION ARE OF PARTICULAR IMPORTANCE. FAILURE TO OBSERVE THIS PRECAUTION COULD RESULT IN SEVERE BODILY INJURY OR LOSS OF LIFE.

WARNING

INSERTING OR REMOVING THE POWER SUPPLY MODULE OR ITS CONNECTING CABLES MAY RESULT IN UNEXPECTED MACHINE MOTION. POWER TO THE MODULE SHOULD BE TURNED OFF BEFORE INSERTING OR REMOVING THE MODULE OR ITS CONNECTING CABLES. FAILURE TO OBSERVE THIS PRECAUTION COULD RESULT IN BODILY INJURY.

WARNING

THE USER MUST PROVIDE AN EXTERNAL, HARDWIRED EMERGENCY STOP CIRCUIT OUTSIDE THE PROGRAMMABLE CONTROLLER CIRCUITRY. THIS CIRCUIT MUST DISABLE THE SYSTEM IN CASE OF IMPROPER OPERATION. UNCONTROLLED MACHINE OPERATION MAY RESULT IF THIS PROCEDURE IS NOT FOLLOWED. FAILURE TO OBSERVE THIS PRECAUTION COULD RESULT IN BODILY INJURY.

CAUTION: The power supply module and racks contain static-sensitive components. Careless handling can cause severe damage. Do not touch the connectors on the back of the power supply module or the racks. When not in use, the power supply module should be stored in an anti-static bag. The plastic cover should not be removed. Failure to observe this precaution could result in damage to or destruction of equipment.

Allen-Bradley and Rockwell Automation are trademarks of Rockwell Automation, Inc.,
Trademarks not belonging to Rockwell Automation are property of their respective companies.

Table of Contents

1.0	Introduction	1-1
1.1	Additional Information	1-1
1.2	Related Hardware and Software	1-2
2.0	Mechanical/Electrical Description	2-1
2.1	Power Supply Module Mechanical Description	2-1
2.1.1	Power Supply Module LED Indicators	2-4
2.1.2	Power Supply Module Terminal Block	2-4
2.1.3	Power Supply Module Battery Connection (M/N 57C493 only)	2-4
2.1.4	Power Supply Module Keyswitch	2-4
2.2	Power Supply Module Electrical Description	2-5
2.3	Rack Mechanical Description	2-5
2.4	Rack Electrical Description	2-6
3.0	Installation	3-1
3.1	Wiring	3-1
3.2	Initial Installation	3-1
3.3	Power Supply Module Replacement	3-5
3.4	Rack Replacement	3-6
4.0	Diagnostics and Troubleshooting	4-1
4.1	The POWER LED Is Off	4-1
4.2	The FAULT LED is On	4-2

Appendices

Appendix A	
Technical Specifications	A-1
Appendix B	
External Connections	B-1
Appendix C	
Rack Backplane	C-1
Appendix D	
Rack Mounting Pattern	D-1
Appendix E	
Power Requirements of AutoMax Modules	E-1

List of Figures

Figure 2.1 - 376W Power Supply Module (M/N 57C493)	2-2
Figure 2.2 - 147W Power Supply Module (M/N 57C494)	2-3
Figure 2.3 - 6-Slot Rack	2-6
Figure 2.4 - 10-Slot Rack	2-6
Figure 2.5 - 16-Slot Rack	2-7
Figure 2.6 - Rack Slot Limitations	2-7
Figure 2.7 - Typical Input Power Connections	2-8

1.0 INTRODUCTION

The products described in this instruction manual are manufactured by Reliance Electric Industrial Company.

The Power Supply module (M/N 57C493 or M/N 57C494) converts 115 VAC input power into the DC voltages necessary to operate the other modules contained in the Rack. The Rack provides the mechanical means of mounting 6 (M/N 57C334), 10 (M/N 57C332), or 16 (M/N 57C331) DCS 5000 or AutoMax modules, as well as the Power Supply module. The Multibus™ backplane in the Rack provides two sets of bus lines for local communication among the DCS 5000 and AutoMax modules.

The M/N 57C393 Power Supply module can provide a maximum continuous output of 376 watts to power modules in the AutoMax rack. The M/N 57C394 Power Supply module can provide a maximum continuous output of 147 watts to power modules in the AutoMax rack. When using the M/N 57C494 Power Supply module in a 10 or 16-slot rack, make certain that the power requirements of the modules in the rack do not exceed the capacity of the Power Supply module. See Appendix E for a list of AutoMax-compatible modules and their power requirements.

This instruction manual describes the functions and specifications of the Power Supply modules and the Rack. It also includes a detailed overview of installation and servicing procedures.

1.1 Additional Information

You should be familiar with the instruction manuals which describe your system configuration. This may include, but is not limited to, the following:

- J-3636 COMMON MEMORY MODULE INSTRUCTION MANUAL
- J-3649 AutoMax CONFIGURATION TASK MANUAL
- J-3630 ReSource AutoMax PROGRAMMING EXECUTIVE INSTRUCTION MANUAL VERSION 1.0
- J-3650 AutoMax PROCESSOR MODULE INSTRUCTION MANUAL
- J-3668 DCS 5000 POCKET REFERENCE
- J-3669 AutoMax POCKET REFERENCE
- J-3675 AutoMax ENHANCED BASIC LANGUAGE INSTRUCTION MANUAL
- J-3676 AutoMax CONTROL BLOCK LANGUAGE INSTRUCTION MANUAL
- J-3677 AutoMax LADDER LOGIC LANGUAGE INSTRUCTION MANUAL
- IEEE 518 GUIDE FOR THE INSTALLATION OF ELECTRICAL EQUIPMENT TO MINIMIZE ELECTRICAL NOISE INPUTS TO CONTROLLERS
- IEEE 796 STANDARD MICROCOMPUTER SYSTEM BUS
- Your ReSource AutoMax PROGRAMMING EXECUTIVE INSTRUCTION MANUAL

- Other instruction manuals applicable to your hardware configuration
- Your personal computer and DOS operating system manual(s).

1.2 Related Hardware and Software

The Power Supply modules and Racks are sold individually. M/N 57C493 contains one 376 watt Power Supply module and two keyswitch keys. M/N 57C494 contains one 147 watt Power Supply module and two keyswitch keys. M/N 57C331 contains one 16-slot Rack. M/N 57C332 contains one 10-slot Rack. M/N 57C334 contains one 6-slot Rack. One Power Supply module and one Rack are used with various input, output, and special purpose modules, as well as the following hardware and software, which can be purchased separately:

1. AutoMax or DCS 5000 Processor modules. The following Processor modules can be used only with the M/N 57C493 Power Supply module: M/N 57C430 AutoMax Processor(s) or M/N 57C407 DCS 5000 Processor(s). Note that all Processors in a single Rack must be of the same type, i.e., AutoMax and DCS 5000 Processors cannot be mixed in one Rack.
 - M/N 57C430 AutoMax Processor
 - M/N 57C407 DCS 5000 Processor

Note that all Processors in a single rack must be of the same type, i.e., AutoMax and DCS 5000 Processors cannot be mixed in the same rack.

The following AutoMax Processors can be used with the M/N 57C493 or M/N 57C494 Power Supply module. These processor modules can be mixed in the same rack:

- M/N 57C430A
 - M/N 57C431
 - M/N 57C435
2. ReSource AutoMax Programming Executive software or ReSource DCS 5000 Programming Executive software.
 3. M/N 57C127 RS-232C ReSource Interface Cable. This cable is used to connect the personal computer to the Processor module.
 4. M/N 57C413 (or later) or M/N 57C423 (or later) Common Memory module. This module is used when there is more than one Processor in the Rack. Note that only M/N 57C413B (and later) or M/N 57C423 (and later) Common Memory module can be used with the M/N 57C494 Power Supply.
 5. M/N 57C492 Battery Back-Up. This unit is used when there is a Common Memory module (M/N 57C413 or M/N 57C413A only), a M/N 57C407 or M/N 57C430 Processor, or both in the Rack. The Battery Back-Up unit can be used only with the M/N 57C493 Power Supply.
 6. M/N 57C384 Battery Back-Up cable. This cable is used with the Battery Back-Up unit.

2.0 MECHANICAL/ELECTRICAL DESCRIPTION

The following is a description of the mechanical and electrical components, as well as the characteristics of the input connections, for the Power Supply module and Racks. Unless noted otherwise, the descriptions that follow describe both M/N 57C493 and M/N 57C494 Power Supply modules.

2.1 Power Supply Module Mechanical Description

The M/N 57C494 Power Supply module is a printed circuit board assembly that plugs into the leftmost position of the 6-, 10-, or 16-Slot Rack. When it is installed in a 10- or 16-Slot Rack, there will be a one-slot-wide space to the right of the Power Supply. If desired, this space can be covered with a blank faceplate (M/N 61C599).

The M/N 57C493 Power Supply module is a printed circuit board assembly that plugs into the leftmost position of either the 10- or 16-Slot Rack. It cannot be used with the 6-Slot Rack. Both modules are enclosed in protective steel housings with integral heatsink. Through its connection to the Multibus backplane of the Rack, the Power Supply module provides the DC voltages necessary to power the logic circuitry of modules in the Rack. On the faceplate of the M/N 57C493 Power Supply module are two LED indicators, a terminal block connector, a keyswitch, a fuse, and a battery back-up connector. See figure 2.1.

On the faceplate of the M/N 57C494 Power Supply module are two LED indicators, a terminal block connector, a keyswitch, and a fuse. See figure 2.2.

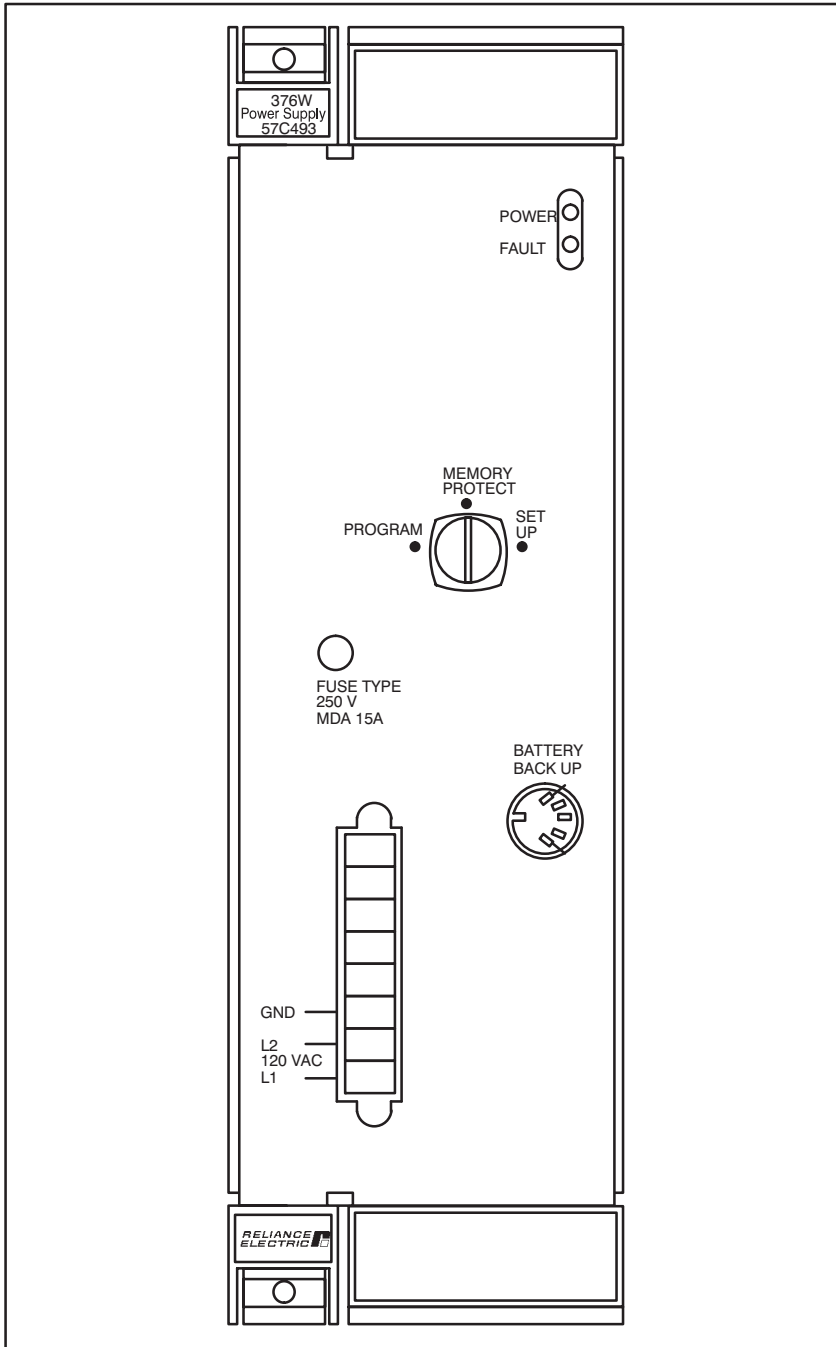

Figure 2.1 - 376W Power Supply Module (M/N 57C493)

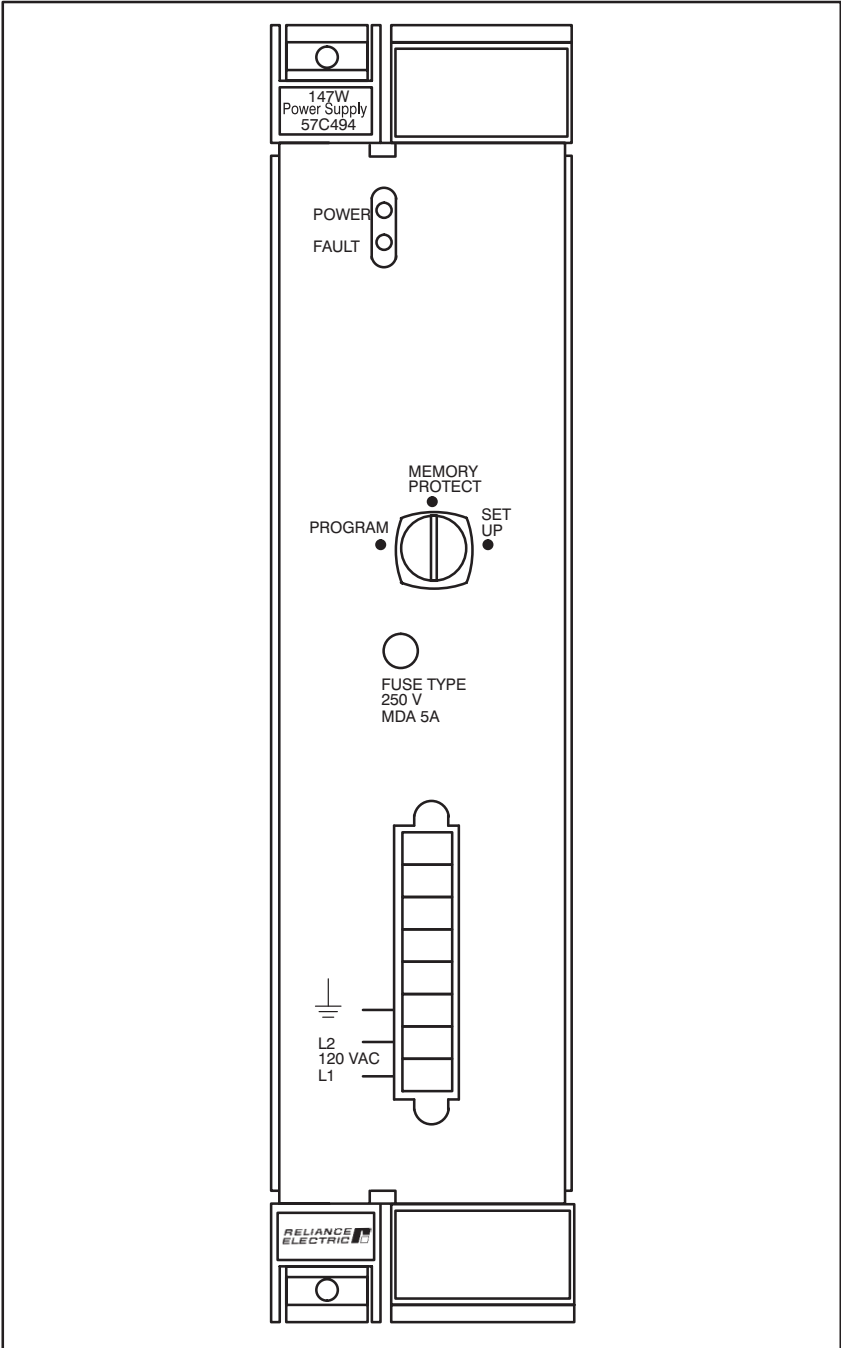

Figure 2.2- 147W Power Supply Module (M/N 57C494)

2.1.1 Power Supply Module LED Indicators

The Power Supply module faceplate contains 2 LEDs. The green LED labeled "POWER" is lit to indicate when incoming AC power is within the specified ranges. The red LED labeled "FAULT" is normally off. When it is on, it indicates the output voltages are not all above the low voltage alarm thresholds or the watchdog OK signal is high.

2.1.2 Power Supply Module Terminal Block

The terminal block on the Power Supply faceplate provides the means to connect the 115 VAC power and a ground wire from the rack to the module. Note that terminals 1–5 (reading top to bottom) are not functional.

The green ground wire from the Rack connects to the "GND" terminal on the faceplate of the Power Supply. Terminal "L2" is the connection for the AC neutral input line from the Rack. Terminal "L1" is the connection for the AC hot input line from the Rack. See section 3.2 for more information.

2.1.3 Power Supply Module Battery Connection (M/N 57C493 only)

The faceplate connection labeled "BATTERY BACK UP" provides the means to connect the Battery Back-Up (M/N 57C492) to the Power Supply module. Note that the Battery Back-Up unit is required only when there is a DCS 5000 Processor module (M/N 57C407) or a Common Memory module (M/N 57C413 or 57C413A only) in the Rack. The Battery Back-Up unit can save the contents of the Common Memory and DCS 5000 Processor RAM in the event of a power failure.

The keyswitch is used to reset the "OK" signal on the Battery Back-Up. It is necessary to reset this signal if the battery fails or if the cable is removed. See 2.1.4 and 2.2 for more information.

Note that the M/N 57C494 Power Supply module does not contain a Battery Back-up connection. Therefore, the above mentioned Processor and Common Memory modules cannot be used with the M/N 57C494 Power Supply.

2.1.4 Power Supply Module Keyswitch

The keyswitch on the faceplate routes TTL signals through the Multibus backplane to the Processor module(s) to allow lockout of programming functions for system security. The three positions of the keyswitch are PROGRAM, MEMORY PROTECT, and SET UP. The position of the keyswitch indicates the security level of the rack, i.e., the kind of ON-LINE Menu operations that can be performed through a personal computer communicating with the processors in the rack. The MEMORY PROTECT position allows only monitoring of variables and saving of tasks from the rack. SETUP allows the operator to monitor all variables, modify tunable variables, and save tasks from the rack. The PROGRAM position allows the operator to perform all ON-LINE Menu functions, providing the password for the rack is also entered. See the appropriate Programming Executive instruction manual for more information.

2.2 Power Supply Module Electrical Description

When the Power Supply module powers-up, it executes a “soft start,” gradually increasing its output until it reaches the voltage necessary for logic operations. At this time, the module generates an initialize signal.

Should the AC input fall below the lower line voltage limit, the module will generate a power fail interrupt signal at least three milliseconds before loss of the regulated DC power to allow for orderly system shutdown. The holdover time on loss of AC input is 20 milliseconds.

In the event of a power fail interrupt signal, 5 Volt output power is supplied by the Battery Back-Up (if installed, M/N 57C493 only) for maintaining the volatile memory of DCS 5000 Processor modules and the Common Memory module. When the regulated output power of the Power Supply module is restored to 4.85 Volts or greater, power will be supplied by the Power Supply module. Note that AutoMax Processors have on-board battery back-up and do not require Battery Back-Up unless there is a Common Memory module (M/N 57C413 or 57C413A only) in the rack.

If Battery Back-Up Voltage ever drops below 3.0 Volts, or the cable between the Battery Back-Up and M/N 57C493 Power Supply module is disconnected with the power off, memory will be lost and the Processor modules will not function until the Power Supply is manually reset by turning the keyswitch on the front panel from MEMORY PROTECT to the PROGRAM position.

2.3 Rack Mechanical Description

The 6-, 10-, and 16-Slot Racks provide the mechanical means for mounting the indicated number of DCS 5000 and AutoMax modules, as well as the Power Supply module. All Racks are designed for panel mounting and include built-in high capacity cooling fans, an AC line filter, a surge protector, and a cable management tray. See figures 2.3, 2.4, and 2.5.

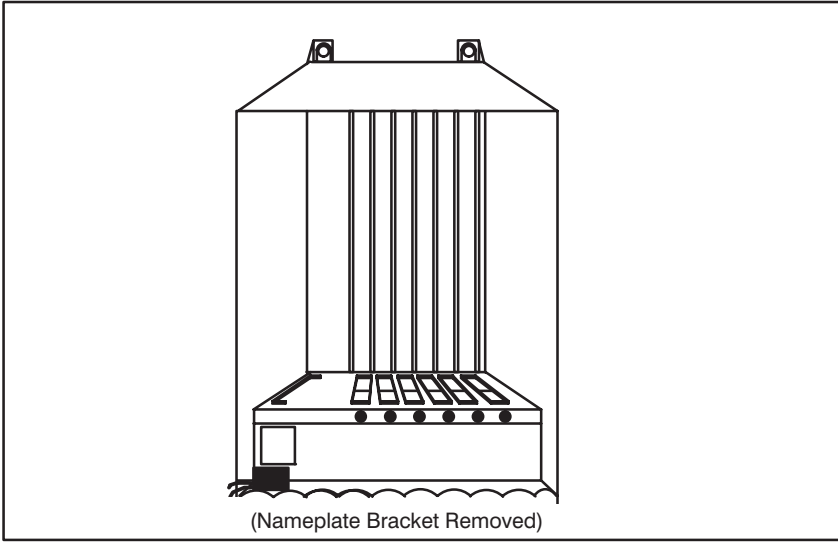

Figure 2.3- 6-Slot Rack

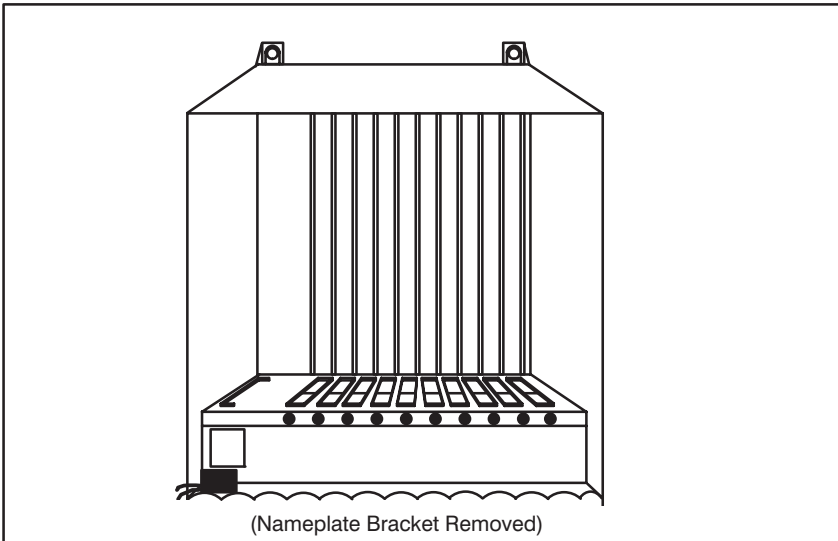

Figure 2.4- 10-Slot Rack

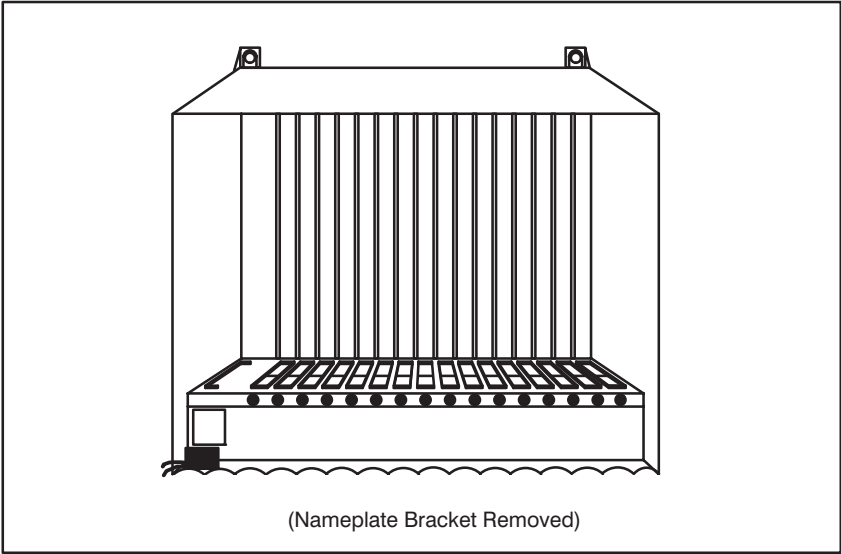

Figure 2.5- 16-Slot Rack

Dedicated signal lines on the Multibus backplane require limitations on slot placement for some types of DCS 5000/AutoMax modules. See figure 2.6.

Module	Module Slot Position															
	0	1	2	3	4	5	6	7	8	9	10	11	12	13	14	15
6-Slot Rack:																
Common Memory	•															
Processor	•	•	•	•	•											
DCS DC Drive ¹																
All Other	•	•	•	•	•	•										
10-Slot Rack:																
Common Memory	•															
Processor	•	•	•	•	•											
DCS DC Drive ²							•	•	•	•						
All Other	•	•	•	•	•	•	•	•	•	•						
16-Slot Rack:																
Common Memory	•															
Processor	•	•	•	•	•											
DCS DC Drive ²							•	•	•	•			•	•	•	•
All Other	•	•	•	•	•	•	•	•	•	•	•	•	•	•	•	•

¹ Cannot be used in a 6-Slot Rack.

² Must be grouped together.

Figure 2.6- Rack Slot Limitations

2.4 Rack Electrical Description

The Multibus backplane of the Rack supports two sets of bus lines that serve as the electrical connection for all slots in the Rack. The P1 bus, the larger of the two electrical connectors, conforms to the IEEE Microcomputer System Bus Standard for the P796 bus, compliance level D16M20116. This bus is used for communication and control signals among the different modules in the Rack. The P2 bus, the smaller of the two backplane electrical connectors, follows a Reliance pin assignment as permitted by the IEEE P796 standard. The P2 bus is used for functions such as determining the slot number of the module. See Appendix C for a description of the pins on the Rack backplane. See J-3649, J-3750, or J2-3045 for guidelines on using non-Reliance modules in the Rack.

The AC line filter on the Rack filters the incoming power signal before it is transmitted to the Power Supply module. The surge protector provides power supply protection from power surges. No other connections to the AC line are permitted between the line filter and the Power Supply module. See figure 2.7 for a typical input power signal.

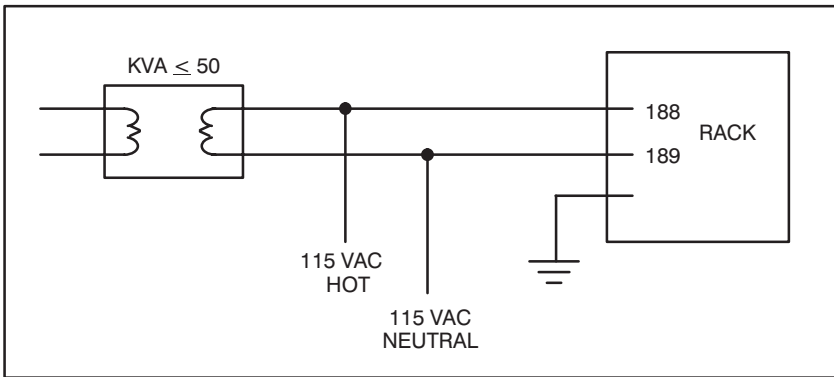

Figure 2.7- Typical Input Power Connections

3.0 INSTALLATION

This section describes how to install and replace the Power Supply module and Rack.

DANGER

THE USER IS RESPONSIBLE FOR CONFORMING WITH ALL APPLICABLE LOCAL, NATIONAL, AND INTERNATIONAL CODES. WIRING PRACTICES, GROUNDING, DISCONNECTS, AND OVER-CURRENT PROTECTION ARE OF PARTICULAR IMPORTANCE. FAILURE TO OBSERVE THIS PRECAUTION COULD RESULT IN SEVERE BODILY INJURY OR LOSS OF LIFE.

CAUTION: This equipment must be connected to a power source for which it was designed. Verify that the available power is 115 volts. Failure to observe this precaution could result in damage to equipment.

3.1 Wiring

To reduce the possibility of electrical noise interfering with the proper operation of the control system, exercise care when installing the wiring between the system and the external devices. For detailed recommendations refer to IEEE 518.

The external wiring to the modules in the Rack must be carefully routed to minimize electrical noise and crosstalk between input and output wiring. Group and bundle wire types by similar electrical signals, being especially careful to separate low- and high-level control signals and AC and DC wiring.

If the 115 VAC input signal is subject to severe harmonic distortion, install a constant voltage transformer on the line.

3.2 Initial Installation

CAUTION: The cabinet or panel on which the rack is mounted must be located in an area away from or shielded from sources of EMI, such as radar beams and transmission towers. Failure to observe this precaution could result in damage to or destruction of the equipment.

CAUTION: Air flow around the rack must be sufficient to dissipate the heat generated by all of the hardware in and around the rack. Allow at least two inches of clearance on each side of the rack. Avoid placing large, heat-generating equipment underneath the rack fans. Additional user-supplied fan cooling or air conditioning is required if the ambient temperature exceeds 60°C. Failure to observe this precaution could result in damage to or destruction of the equipment.

CAUTION: The rack must be located in a clean environment. Do not expose the rack to dripping water or corrosive atmospheres containing carbon dust, metal particles, or other contaminants. Failure to observe this precaution could result in damage to or destruction of the equipment.

Use the following procedure to install the Rack and Power Supply module. Before you begin, make certain that you have provided enough space for the Rack, wiring, and terminal strips or other devices that must be mounted near the Rack. Make certain that the panel is sturdy enough to support the Rack and all modules that it will hold. Including connectors attached to module faceplates, a fully-loaded 6-Slot Rack weighs approximately 40 lbs. A fully-loaded 10-Slot Rack weighs between 70 and 80 lbs. A fully-loaded 16-Slot Rack weighs between 105-115 lbs.

Step 1. Mount the Rack on a panel or cabinet made of heavy gauge steel sturdy enough to hold the Rack, all of the hardware modules that will go into the Rack, and the terminal strip/connector assemblies for I/O modules. The connector end of each terminal strip/connector assembly is attached to the appropriate module faceplate. The terminal strip end of each assembly can be mounted on the panel itself or on lashing bars attached to the panel. Refer to the instruction manual for each individual module in your installation for more specific information. Follow the procedure below to install the Rack.

- a) Drill four holes in the panel using the appropriate mounting pattern in Appendix D.
- b) In each hole, screw in one 1 1/4" 20-thread Tap tite™ bolt, leaving approximately 1/8" to 1/4" of the thread exposed.
- c) Remove the large nameplate bracket (labeled "AutoMax") from the rack by removing the three screws near the base holding it to the cable guide area.
- d) Position the Rack against the panel at a slight angle so that the bottom is a few inches away from the panel. Place the top of the Rack against the panel so that the upper two bolts are visible through the larger part of the bolt holes at the top of the Rack.

Carefully slide the Rack down so that the bolts are wedged in the top (smaller) area of the bolt holes, while at the same time moving the lower portion of the Rack toward the cabinet or panel onto the lower bolts. The lower bolts should be firmly wedged against the upper edge of the lower bolt holes on the Rack. Tighten all the bolts.

Step 2. Mount the Power Supply module in the Rack following the steps below.

- a) Take the Power Supply module out of its shipping container and anti-static bag, being careful not to touch the connectors on the back of the module.
- b) Remove the two keyswitch keys which are taped to the front of the module. Insert the module into the leftmost and widest slot in the Rack. Use a screwdriver to attach

the module to the Rack. Store the keyswitch keys in a secure area.

- c) Connect the Battery Back-Up unit, if used. Plug one end of the Battery Back-Up cable into the Power Supply module faceplate connector labeled "BATTERY BACK UP". Plug the other end of the cable into the Battery Back-Up unit. Rotate the keyswitch on the front panel from Memory Protect to the Program position.

Step 3. Mount the terminal strip end of the terminal strip/connector assemblies for I/O modules on the panel or on lashing bars. The terminal strips should be mounted to permit easy access to the screw terminals. Make certain that the strips are close enough to the Rack so that the connecting cables will reach between terminal strips and the modules. Most cables are approximately 60" long.

Step 4. Fasten wiring for the external hardware to the terminal strips. Make certain that all field wires are securely attached. Label all terminal strips and field wires to allow easy reconnection at a later date.

For I/O modules, note carefully that bit numbers and wire numbers (located on wires between the faceplate connector and terminal strip) are not the same. Refer to the installation section of the instruction manuals describing the I/O modules for more information.

Step 5. Take the Processor module(s) and other modules out of their shipping containers and insert them into the desired slots. See figure 2.6 for slot restrictions for certain modules. Use a screwdriver to attach the modules to the Rack.

Step 6. Attach the connector ends of the terminal strip/connector assemblies to their mating halves on the appropriate modules. Use a screwdriver to attach the connectors to the modules. Use the cable guides at the base of the rack to keep cables separate.

Note that in most cases both the connectors and their mating halves are equipped with movable "keys". These keys should be used to prevent the wrong connector from being plugged into a module in the event that the connector needs to be removed and then re-attached later.

At the time of installation, rotate the keys on the connector and the mating half on the module to mirror image positions so that they can be connected together securely. For all modules equipped with keys, the key on each successive module in the Rack should be rotated one position to the right of the key on the preceding module.

Step 7. Wire the Rack following the instructions below.

CAUTION: Do not connect incoming AC power directly to the power supply module faceplate. Connect AC power to the correct terminals on the rack only. Failure to observe this precaution could result in damage to or destruction of the equipment.

- a) Ground the cabinet or panel on which the Rack will be mounted. Make certain that there is an unbroken path from the cabinet to the plant ground (earth).
- b) Ground the rack with a ground wire connected to one of the protective ground terminals provided on each side of the rack. The ground wire color and size must be in accordance with appropriate international and national standards and codes.
- c) Connect incoming AC power to the Rack as follows:

Rack Terminal Label	Input
189	120 VAC
188	120 VAC + (hot)

Cover the incoming wire ends with a Faston™ connector and attach them securely to the appropriate terminals using a screwdriver.

- d) Connect the power and ground wires from the Rack to the Power Supply module as follows:

Wire Color	Wire Label	Power Supply Faceplate Connector
black	L2	L2
orange	L1	L1
green	–	GND

The wires labeled L2 and L1 should remain twisted together as much as possible between the Rack and the Power Supply module.

- Step 8. Using a screwdriver, re-attach the nameplate bracket to the base of the rack.
- Step 9. Turn on power to the system.

DANGER

THE POWER SUPPLY MODULE OPERATES USING AC INPUT VOLTAGE CAPABLE OF PRODUCING SEVERE SHOCK. MAKE CERTAIN THAT THE EXTERNAL AC SUPPLY CIRCUIT IS TURNED OFF BEFORE INSERTING OR REMOVING THE MODULE OR ANY CONNECTING CABLES. FAILURE TO OBSERVE THIS PRECAUTION COULD RESULT IN SEVERE BODILY INJURY OR LOSS OF LIFE.

- Step 10. Verify the installation by connecting the personal computer to the port labeled “PROGRAMMER/PORT B” on the leftmost Processor in the Rack and running the ReSource programming software. Try to read from or write to the registers on each of the modules in the Rack.

WARNING

BE CAREFUL TO INSURE THAT NO UNEXPECTED MACHINE MOTION WILL RESULT WHEN WRITING TO OUTPUTS. FAILURE TO OBSERVE THIS PRECAUTION COULD RESULT IN BODILY INJURY.

Refer to the instruction manuals describing other hardware in the installation for more information.

3.3 Power Supply Module Replacement

Use the following procedure to replace the Power Supply module:

Step 1. Turn off power to the Rack and all connections.

DANGER

THE POWER SUPPLY MODULE OPERATES USING AC INPUT VOLTAGE CAPABLE OF PRODUCING SEVERE SHOCK. MAKE CERTAIN THAT THE EXTERNAL AC SUPPLY CIRCUIT IS TURNED OFF BEFORE INSERTING OR REMOVING THE MODULE OR ANY CONNECTING CABLES. FAILURE TO OBSERVE THIS PRECAUTION COULD RESULT IN SEVERE BODILY INJURY OR LOSS OF LIFE.

Step 2. Use a screwdriver to disconnect the terminal strip from the Power Supply module. Do not remove the wires from the terminal strip. Disconnect the Battery Back-Up cable, if used.

Remove the nameplate bracket from the rack by removing the three screws near the base holding it to the cable guide area.

Step 3. Use a screwdriver to loosen the screws holding the Power Supply module in the Rack and remove the module, being careful not to touch the connectors on the back. Store the module in the anti-static bag it came in.

Step 4. Mount the replacement Power Supply module in the Rack following the steps below:

- a) Take the replacement Power Supply module out of its shipping container and anti-static bag, being careful not to touch the connectors on the back of the module.
- b) Remove the two keys to the keyswitch which are taped to the front of the module. Store the keyswitch keys in a secure area. Use a screwdriver to disconnect the terminal strip from the replacement Power Supply module.
- c) Insert the module into the leftmost and widest slot in the Rack. Use a screwdriver to attach the module to the Rack.
- d) Use a screwdriver to attach the terminal strip from the old Power Supply module to the replacement Power Supply module. Make certain that the connector is attached correctly by verifying that the wiring and the terminal labels on the faceplate match as follows:

Wire Color	Wire Label	Power Supply Faceplate Connector
black	L2	L2
orange	L1	L1
green	–	GND

- e) If you are using the Battery Back-Up unit, plug one end of the Battery Back-Up cable into the Power Supply module faceplate connector labeled “BATTERY BACK UP”. Plug the other end into the Battery Back-Up unit. Rotate the keyswitch on the front panel from Memory Protect to the Program position.
- f) Using a screwdriver, re-attach the nameplate bracket to the base of the rack.

- Step 5. Turn on power to the system.
- Step 6. Verify the installation by connecting the personal computer to the port labeled “PROGRAMMER/PORT B” on the leftmost Processor in the Rack and running the ReSource programming software. Try to read from or write to the registers on each of the modules in the Rack.

WARNING
BE CAREFUL TO INSURE THAT NO UNEXPECTED MACHINE MOTION WILL RESULT WHEN WRITING TO OUTPUTS. FAILURE TO OBSERVE THIS PRECAUTION COULD RESULT IN BODILY INJURY OR DAMAGE TO EQUIPMENT.

Refer to the instruction manuals describing the specific hardware in the installation for more information.

3.4 Rack Replacement

Use the following procedure to replace the Rack:

- Step 1. Turn off power to the Rack and all connections.

DANGER
THE POWER SUPPLY MODULE OPERATES USING AC INPUT VOLTAGE CAPABLE OF PRODUCING SEVERE SHOCK. MAKE CERTAIN THAT THE EXTERNAL AC SUPPLY CIRCUIT IS TURNED OFF BEFORE INSERTING OR REMOVING THE MODULE OR ANY CONNECTING WIRES. FAILURE TO OBSERVE THIS PRECAUTION COULD RESULT IN SEVERE BODILY INJURY OR LOSS OF LIFE.

- Step 2. Using a screwdriver, remove the nameplate bracket from the rack by removing the three screws near the base holding it to the cable guide area. Loosen all the screws holding connectors to the modules in the Rack. Remove the connectors. Disconnect the wires attached to the terminal strip on the Power Supply module.
- Step 3. Use a screwdriver to loosen the screws holding all modules, including the Power Supply module, in the Rack.

Take all of the modules out of the Rack, being careful not to touch the connectors on the back.

- Step 4. Loosen the bolts that hold the rack to panel approximately 1/8" – 1/4". Lift the Rack slightly while holding it against the panel until both top bolts are positioned in the larger bolt holes and the lower two bolts have cleared the smaller holes. Pull the Rack away from the panel and set aside.
- Step 5. Position the replacement Rack against the panel at a slight angle so that the bottom is a few inches away from the panel. Place the Rack against the panel so that the upper two bolts are visible through the larger part of the bolt holes at the top of the Rack.
- Carefully slide the Rack down so that the bolts are wedged in the top (smaller) area of the bolt holes, while at the same time moving the lower portion of the Rack toward the cabinet or panel onto the lower bolts. The lower bolts should be firmly wedged against the upper edge of the lower bolt holes on the Rack. Tighten all the bolts.
- Step 6. Insert the Power Supply module into the leftmost and widest slot in the Rack. Use a screwdriver to attach the module to the Rack.
- Step 7. If you are using the Battery Back-Up unit, plug one end of the Battery Back-Up cable into the Power Supply module faceplate connector labeled "BATTERY BACK UP". Plug the other end into the Battery Back-Up unit. Rotate the keyswitch on the front panel from Memory Protect to the Program position.
- Step 8. Insert the Processor module(s) and other modules. Use a screwdriver to attach the modules to the Rack.
- Step 9. Use a screwdriver to attach the connectors to their mating halves on the appropriate modules.
- Step 10. Connect 115 VAC power to the Rack following the instructions below.

CAUTION: Do not connect incoming AC power directly to the power supply module faceplate. Connect power to the correct terminals on the rack only. Failure to observe this precaution could result in damage to or destruction of the equipment.

- a) Make certain that there is an unbroken path from the cabinet to the plant ground.
- b) Connect incoming AC power to the Rack as follows:

Rack Terminal Label	Input
189	120 VAC
188	120 VAC + (hot)

Cover the incoming wire ends with a Faston™ connector and attach them securely to the appropriate terminals using a screwdriver.

- c) Connect the power and ground wires from the Rack to the Power Supply module as follows:

Wire Color	Wire Label	Power Supply Faceplate Connector
black	L2	L2
orange	L1	L1
green	–	GND

The wires labeled L2 and L1 should remain twisted together as much as possible between the Rack and the Power Supply module.

- Step 11. Using a screwdriver, re-attach the nameplate bracket to the base of the rack.
- Step 12. Turn on power to the system.
- Step 13. Verify the installation by connecting the personal computer to the port labeled “PROGRAMMER/PORT B” on the leftmost Processor in the Rack and running the ReSource programming software. Try to read from or write to the registers on each of the modules in the Rack.

WARNING

WHEN WRITING TO OUTPUTS, BE CAREFUL TO INSURE THAT NO UNEXPECTED MACHINE MOTION WILL RESULT. FAILURE TO OBSERVE THIS PRECAUTION COULD RESULT IN BODILY INJURY OR DAMAGE TO EQUIPMENT.

Refer to the instruction manuals describing the specific hardware in the installation for more information.

4.0 DIAGNOSTICS AND TROUBLESHOOTING

This section explains how to troubleshoot the Power Supply module and Rack. Any problems with either the Power Supply module or the Rack can usually be isolated by observing the condition of the LEDs on the Power Supply module faceplate. Problems with the Rack backplane (bus) will result in error codes on the LEDs of Processor modules in the Rack. See J-3650 for more information on troubleshooting the AutoMax Processor module.

DANGER

THE POWER SUPPLY MODULE OPERATES USING AC INPUT VOLTAGE CAPABLE OF PRODUCING SEVERE SHOCK. MAKE CERTAIN THAT THE EXTERNAL AC SUPPLY CIRCUIT IS TURNED OFF BEFORE INSERTING OR REMOVING THE MODULE OR ANY CONNECTING WIRES. FAILURE TO OBSERVE THIS PRECAUTION COULD RESULT IN SEVERE BODILY INJURY OR LOSS OF LIFE.

If the problem cannot be determined using the troubleshooting instructions below, the hardware is not user-serviceable.

DANGER

SOME OF THESE STEPS ARE MADE WITH POWER ON. EXERCISE EXTREME CARE BECAUSE HAZARDOUS VOLTAGE EXISTS. FAILURE TO OBSERVE THIS PRECAUTION COULD RESULT IN SEVERE BODILY INJURY OR LOSS OF LIFE.

4.1 The POWER LED Is Off

Problem: the POWER LED on the Power Supply module is off. This LED should always be on when input power is on and the input fuse is in place and functioning correctly. If the LED is off, the module is not receiving 120 VAC power. Use the following procedure to isolate the problem.

- Step 1. Using a voltmeter, verify that the Rack is receiving 120 VAC power.
- Step 2. Turn off power to the Rack. Wait until all of the LEDs on the faceplate of the Power Supply module have gone out. Verify that the connections at the Rack and the L1 and L2 connections at the Power Supply module are tight.
- Step 3. Remove the fuse cap and fuse and, using an Ohm meter, verify that the fuse is not blown. If the fuse is good, re-insert it and continue with step 4.

If the fuse is blown, verify that, for M/N 57C493, it is a 15A MDA time delay type fuse. M/N 57C494 should contain a 5A MDA time delay type fuse. A blown fuse indicates that the Power Supply should be replaced.
- Step 4. Turn on power to the Rack. If the problem is not corrected, replace the Power Supply.

4.2 The FAULT LED is On

Problem: the FAULT LED on the Power Supply module is ON. This LED should always be off when input power is on, the Power Supply output voltage is within proper limits, and the watchdog alarm coming from the backplane is not active. The rack must also contain at least one AutoMax Processor module (or, for a remote rack, a Remote I/O module). Note that the FAULT LED will be ON if there is no Processor (or Remote I/O module) in the rack.

Use the following procedure to determine whether the problem is caused by a malfunctioning Power Supply or by a watchdog alarm.

- Step 1. Verify that the Power Supply is securely seated in the rack. The FAULT LED will come ON if there is not a good connection to the rack backplane.
- Step 2. If you have more than one Processor in the rack, a watchdog timeout will not be indicated by the Power Supply FAULT LED. If the Power Supply FAULT LED is ON, the Power Supply must be replaced.

If the rack contains a single AutoMax Processor or is a remote rack, check the OK LED on the Processor module or Remote I/O module. If the OK LED is OFF, it may indicate a watchdog timeout.
- Step 3. Turn off power to the rack. Replace the Processor or Remote I/O module. Turn on power to the rack.
- Step 4. If the Power Supply FAULT LED turns ON, the Power Supply is malfunctioning. Replace the Power Supply.

Appendix A

Technical Specifications Power Supply Module (M/N 57C493)

Ambient Conditions

- Storage temperature: $-40^{\circ}\text{C} - 85^{\circ}\text{C}$
- Operating temperature: $0^{\circ}\text{C} - 60^{\circ}\text{C}$
- Humidity: 5–90% non-condensing
- Altitude: operation from sea level at 60°C to 10,000 feet (3048 meters) with linear derating of 1°C per 1000 feet above 5000 feet.

Dimensions

- Height: 29.8 cm $11\frac{3}{4}$ inches
- Width: 10.2 cm 4 inches
- Depth: 19.7 cm $7\frac{3}{4}$ inches
- Weight: 3.8 kg $8\frac{1}{2}$ lbs

System Power Requirements

- Input voltage: nominal 100/120 VAC, 85-132 VAC acceptable range
- Current: 6 Amp at 120 VAC
- Frequency: nominal 50/60 Hz, 47-63 Hz acceptable range
- Protection: 15 Amp 250 VAC MDA time delay fuse
- Fault current limit: 10,000 Amps
- Maximum source rating: 50KVA

DC Output

- +5 VDC at 50 amps
- ± 12 VDC at 4 amps
- ± 15 VDC at 1 amp
- Maximum continuous output power: 376 Watts
- Holdup time: 20 msec. minimum after loss of AC input

Regulation

- Nominal +5 VDC: -2.5% to $+3\%$ regulation
- Nominal ± 12 VDC: $\pm 10\%$ regulation
- Nominal ± 15 VDC: $\pm 1\%$ regulation

Efficiency

- 75% minimum at nominal line voltage and full load

Isolation

- 1500 VDC for 1 sec input to output and input to chassis
- 700 VDC for 1 sec output to chassis

Protection

- Overvoltage: +5V $5.6\text{V} \pm 0.15\text{V}$
 $\pm 12\text{V}$ $14.4\text{V} \pm 0.6\text{V}$
 $\pm 15\text{V}$ $16.5\text{V} \pm 0.5\text{V}$

Technical Specifications

Power Supply Module (M/N 57C494)

Ambient Conditions

- Storage temperature: $-40^{\circ}\text{C} - 85^{\circ}\text{C}$
- Operating temperature: $0^{\circ}\text{C} - 60^{\circ}\text{C}$
- Humidity: 5–90% non-condensing
- Altitude: operation from sea level at 60°C to 10,000 feet (3048 meters) with linear derating of 1°C per 1000 feet above 5000 feet.

Dimensions

- Height: 29.8 cm $11\frac{3}{4}$ inches
- Width: 7.1 cm $2\frac{13}{16}$ inches
- Depth: 19.7 cm $7\frac{3}{4}$ inches
- Weight: 2.6 kg $5\frac{3}{4}$ lbs

System Power Requirements

- Input voltage: nominal 100/120 VAC, 85-132 VAC acceptable range
- Current: 2.6 Amp at 120 VAC
- Frequency: nominal 50/60 Hz, 47-63 Hz acceptable range
- Protection: 5 Amp 250 VAC MDA time delay fuse
- Fault current limit: 10,000 Amps
- Maximum source rating: 50KVA

DC Output

- +5 VDC at 20 amps
- +/- 12 VDC at 1 amp
- +/- 15 VDC at 0.75 amp
- Maximum continuous output power: 147 Watts
- +5 VDC output holdup time: 3 msec. minimum after loss of AC input at full load and minimum input line voltage
- Input line loss: capable of a 1 cycle 60 Hz line loss at nominal input line voltage

Regulation

- Nominal +5 VDC: -2.5% to $+3\%$ regulation
- Nominal +/- 12 VDC: +/- 10% regulation
- Nominal +/- 15 VDC: +/- 1% regulation

Efficiency

- 65% minimum at nominal line voltage and full load

Isolation

- 1500 VDC input to output
- 700 VDC output to chassis

Protection

- Overvoltage: +5V $5.6\text{V} +/- 0.15\text{V}$
+/- 12V $14.4\text{V} +/- 0.6\text{V}$
+/- 15V $16.5\text{V} +/- 0.5\text{V}$

Technical Specifications

16-Slot, 10-Slot and 6-Slot Rack

Ambient Conditions

- Storage temperature: -55°C - 85°C
- Operating temperature: 0°C - 60°C
- Humidity: 5-90% non-condensing

Rack Dimensions

M/N 57C331 16-Slot Rack

- Height: 48.6 cm 19¹/₈ inches
- Width: 62.4 cm 24⁹/₁₆ inches
- Depth: 31.1 cm 12¹/₄ inches
- Approximate Weight: 50 kg fully loaded 110 lbs

M/N 57C332 10-Slot Rack

- Height: 48.6 cm 19¹/₈ inches
- Width: 43.3 cm 17¹/₁₆ inches
- Depth: 31.1 cm 12¹/₄ inches
- Approximate Weight: 34 kg fully loaded 75 lbs

M/N 57C334 6-Slot Rack

- Height: 48.6 cm 19¹/₈ inches
- Width: 27.5 cm 10³/₁₆ inches
- Depth: 31.1 cm 12¹/₄ inches
- Approximate Weight: 18 kg fully loaded 39.5 lbs

Bus Specifications

- Type: Intel Multibus™
- P1 bus connector: IEEE standard P796 bus
- P2 bus connector: IEEE standard P796 modified bus

AC Line Filter:

- 10 Amp (M/N 57C331 and M/N 57C332)
- 6 Amp (M/N 57C334)
- 120/250 VAC
- 50/60 Hz

Fans

- Two (2) per Rack (M/N 57C331 and M/N 57C332)
- One (1) per Rack (M/N 57C334)
- Nominal power dissipation: 14 Watts each

Appendix B

External Connections

Input Power to Rack (M/N 57C331, 57C332, and 57C334)

Terminal Label	Input
189	AC neutral
188	AC hot
GND	Rack/earth ground

Rack (M/N 57C331 and 57C332) to Power Supply Module (M/N 57C493)

Wire Color	Wire Label	Power Supply Faceplate Connector
black	L2	L2
orange	L1	L1
green	–	GND

Rack (M/N 57C331, 57C332, and 57C334) to Power Supply Module (M/N 57C494)

Wire Color	Wire Label	Power Supply Faceplate Connector
black	L2	L2
orange	L1	L1
green	–	GND

Appendix C

Rack Backplane

P1 Bus

	Component Side		
	Pin ¹	Mnemonic	Description
Power Supplies	1	GND	Signal Ground
	3	+5V	+5 VDC
	5	+5V	+5 VDC
	7	+12V	+12 VDC
	9 NC	-5V	-5 VDC
	11	GND	Signal Ground
Bus Controls	13	BCLK	Bus Clock
	15	BPRN/	Bus Priority In
	17	BUSY/	Bus Busy
	19	MRDC/	Memory Read Command
	21	IORC/	I/O Read Command
	23	XACK/	Transfer Acknowledge
Bus Controls and Addresses	25	LOCK/	Lock
	27	BHEN/	Byte Hi Enable
	29	CBRQ/	Common Bus Request
	31	CCLK/	Common Clock
	33 NC	INTA/	Interrupt Acknowledge
Parallel Interrupts Requests	35 MOD	INT6/	CPU Communication Interrupt
	37 NC	INT4/	General Purpose Interrupt
	39	INT2/	General Purpose Interrupt
	41	INT0/	General Purpose Interrupt
Address	43	ADRE/	Address Bus
	45	ADRC/	
	47	ADRA/	
	49	ADR8/	
	51	ADR6/	
	53	ADR4/	
	55	ADR2/	
	57	ADR0/	
Data	59	DATE/	Data Bus
	61	DATC/	
	63	DATA/	
	65	DAT8/	
	67	DAT6/	
	69	DAT4/	
	71	DAT2/	
	73	DAT0/	
Power Supplies	75	GND	Signal Ground
	77 NC		Reserved
	79	-12V	-12V
	81	+5V	+5 VDC
	83	+5V	+5 VDC
	85	GND	Signal Ground

NC: No connection

MOD: Modified definition of Multibus specification

NU: No usage in system; driven per Multibus specification

Rack Backplane (Cont.)

P1 Bus (Cont.)

	Solder Side		
	Pin ¹	Mnemonic	Description
Power Supplies	2	GND	Signal Ground
	4	+5V	+5 VDC
	6	+5V	+5 VDC
	8	+12V	+12 VDC
	10 NC	-5V	-5 VDC
	12	GND	Signal Ground
Bus Controls	14	INIT/	Initialize
	16	BPRO/	Bus Priority Out
	18	BREQ/	Bus Request
	20	MWTC/	Memory Write Command
	22	IOWC/	I/O Write Command
Bus Controls and Addresses	24 MOD	PRIV/	Privilege
	26 MOD	MMUMAP	MMU Map Select
	28	AD10/	Address Bus
	30	AD11/	Address Bus
	32	AD12/	Address Bus
Parallel Interrupts Requests	34	AD13/	Address Bus
	36 MOD	INT7/	System WDOG Interrupt
	38 NC	INT5/	General Purpose Interrupt
	40	INT3/	General Purpose Interrupt
Address	42	INT1/	General Purpose Interrupt
	44	ADR/	Address Bus
	46	ADR/	
	48	ADRB/	
	50	ADR9/	
	52	ADR7/	
	54	ADR5/	
56	ADR3/		
Data	58	ADR1/	
	60	DATF/	Data Bus
	62	DATD/	
	64	DATB/	
	66	DAT9/	
	68	DAT7/	
	70	DAT5/	
72	DAT3/		
Power Supplies	74	DAT1/	
	76	GND	Signal Ground
	78 NC		Reserved
	80	-12V	-12V
	82	+5V	+5 VDC
	84	+5V	+5 VDC
86	GND	Signal Ground	

NC: No connection

MOD: Modified definition of Multibus specification

NU: No usage in system; driven per Multibus specification

Rack Backplane (Cont.)

P2 Bus

Component Side		
Pin	Mnemonic	Description
1	AGND	Analog Ground
3	5VB	+5V Battery
5	IDA0/	Address ID #0
7	DB	Dedicated High Speed Bus
9	IDA1/	Address ID #1
11	DB	Dedicated High Speed Bus
13	DB	Dedicated High Speed Bus
15	DB	Dedicated High Speed Bus
17	PFSN/	Power Fail Sense
19	PFIN/	Power Fail Interrupt
21	AGND	Analog Ground
23	A +15V	Analog +5 VDC
25	A -15V	Analog +5 VDC
27	DB DPR0/	Data Parity 0
29	DB APR0/	ADDR Parity 0
31	DB APR2/	ADDR Parity 2
33	DB	Dedicated High Speed Bus
35	KEY0/	Key Lock Position 0
37	KEY1/	Key Lock Position 1
39	WDOK/	Watchdog OK
41	MPOSO	Dedicated High Speed Bus
43	MPOS2/	Dedicated High Speed Bus
45	MPOS4/	Dedicated High Speed Bus
47	MPOS6/	Dedicated High Speed Bus
49	MPOS8/	Dedicated High Speed Bus
51	MPOSA/	Dedicated High Speed Bus
53	MPOSC/	Dedicated High Speed Bus
55	MPOSE/	Dedicated High Speed Bus
57	MDFLT/	Dedicated High Speed Bus
59	MVAGND	Dedicated High Speed Bus

Rack Backplane (Cont.)

P2 Bus (Cont.)

Solder Side		
Pin	Mnemonic	Description
2	AGND	Analog Ground
4	5VB	+5V Battery
6	DBR	Dedicated High Speed Bus
8	DBR	Dedicated High Speed Bus
10	IDA2/	Address ID #2
12	DB	Dedicated High Speed Bus
14	IDA3/	Address ID #3
16	DBR	Dedicated High Speed Bus
18	DBR	Dedicated High Speed Bus
20	MPRO/	Memory Protect
22	AGND	Analog Ground
24	A +15V	Analog +15 VDC
26	A -15V	Analog -15 VDC
28	DPR1/	Data Parity 1
30	APR1/	ADDR Parity 1
32	PREN/	Parity Enable
34	DIAG/	Diagnostic Loop
36	BD RST/	Board Reset
38	DB	Dedicated High Speed Bus
40	DB	Dedicated High Speed Bus
42	MPOS1	Dedicated High Speed Bus
44	MPOS3/	Dedicated High Speed Bus
46	MPOS5/	Dedicated High Speed Bus
48	MPOS7/	Dedicated High Speed Bus
50	MPOS9/	Dedicated High Speed Bus
52	MPOSB/	Dedicated High Speed Bus
54	MPOSD/	Dedicated High Speed Bus
56	MPOSF/	Dedicated High Speed Bus
58	MVAREF	Dedicated High Speed Bus
60	MVAGND	Dedicated High Speed Bus

Appendix D

Rack Mounting Pattern

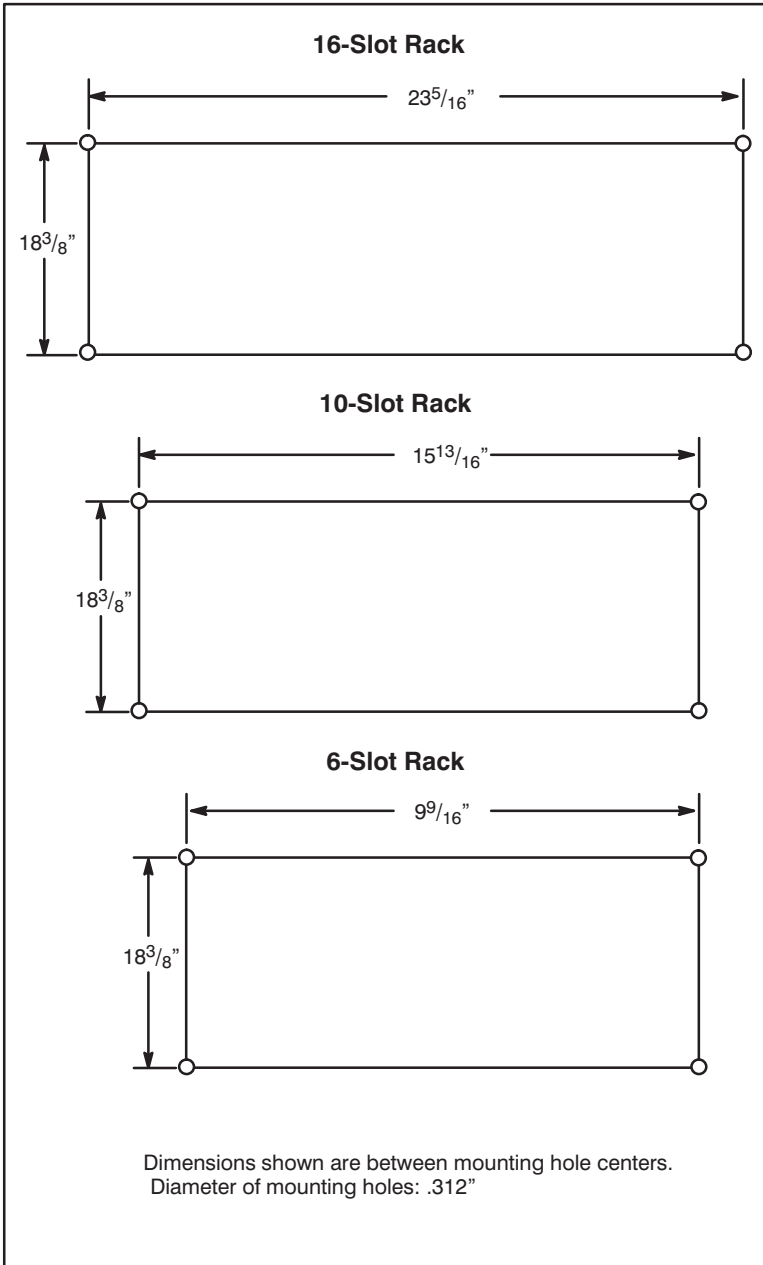

Appendix E

Power Requirements of AutoMax Modules

Note: Values are in amps.

Module	Description	+5V	+12V	-12V	+15V	-15V
M/N 57C400	115VAC/DC Input	0.425	0	0	0	0
B/M 57401-1	Drive Digital I/O	0.375	0.1	0.015	0	0
M/N 57C402	24–115VAC/DC Output	0.525	0.045	0.045	0	0
M/N 57C403	115V High Output	1.2	0	0	0	0
M/N 57C404	Network Communication	2.5	0.053	0.0075	0	0
B/M 57405	Drive Analog I/O	1.2	0.1	0.1	0.15	0.15
M/N 57C409	Analog Input	3.05	0	0	0	0
M/N 57C410	Analog Output	2.75	0.055	0.005	0	0
M/N 57C411	Resolver Input	1.7	0.095	0.095	0	0
M/N 57C413	Common Memory	1.05	0	0	0	0
M/N 57C414	Modbus Interface	2.5	0.053	0.0075	0	
M/N 57C415	24VAC/DC Input	0.625	0	0	0	0
M/N 57C416	Remote I/O Communications	2.5	0.053	0.0075	0	
M/N 57C417	AutoMate Interface	2.5	0.053	0.0075	0	
M/N 57C418	A–B Interface	2.5	0.053	0.0075	0	
M/N 57C419	5–24VDC Input	0.7	0	0	0	0
M/N 57C420	5–24VDC Output	0.85	0	0	0	0
M/N 57C421	Pulsetach Input	0.9	0	0	0	0
M/N 57C422	2–Axis Servo	1.6	0	0	0	0
M/N 57C423	Common Memory	1.05	0	0	0	0
M/N 57C428	Toledo Scale Interface	2.4	0.053	0.008	0	0
M/N 57C429	AutoMax R–Net Processor	2.5	0.03	0	0	0
M/N 57C430	AutoMax Processor	3.0	0.1	0.1	0	0
M/N 57C431	AutoMax Processor	3.0	0.1	0.1	0	0
M/N 57C435	AutoMax Processor	3.0	0.1	0.1	0	0
M/N 57C440	Ethernet Interface	5.0	0.5	0.1	0	0

Power Requirements of AutoMax Modules (Cont.)

Note: Values are in amps.

Module	Description	+5V	+12V	-12V	+15V	-15V
M/N 57C441	Modbus Plus Interface	0.6	0	0	0	0
M/N 57C442	Data Highway Plus Interface	0.65	0	0	0	0
B/M 57552	Universal Drive Controller	1.7	0	0	0.1	0.071
M/N 61C500	115VAC Input	1.2	0	0	0	0
M/N 61C515	24VAC/DC Input	1.2	0	0	0	0
M/N 61C540	Current Input	1.5	0.03	0	0	0
M/N 61C542	Voltage Input	1.5	0.03	0	0	0
M/N 61C544	RTD	1.5	0.03	0	0	0
M/N 61C605	8-Ch. Thermocouple Input	1.6	0	0	0	0
M/N 61C613	16-Channel Analog Input	1.25	0	0	0	0

For additional information

1 Allen-Bradley Drive

Mayfield Heights, Ohio 44124 USA

Tel: +1 440 646-3434

<http://www.rockwellautomation.com/support>

www.rockwellautomation.com

Power, Control and Information Solutions Headquarters

Americas: Rockwell Automation, 1201 South Second Street, Milwaukee, WI 53204-2496 USA, Tel: (1) 414.382.2000, Fax: (1) 414.382.4444

Europe/Middle East/Africa: Rockwell Automation NV, Pegasus Park, De Kleetlaan 12a, 1831 Diegem, Belgium, Tel: (32) 2 663 0600, Fax: (32) 2 663 0640

Asia Pacific: Rockwell Automation, Level 14, Core F, Cyberport 3, 100 Cyberport Road, Hong Kong, Tel: (852) 2887 4788, Fax: (852) 2508 1846

Publication J2-3008-4 - September 1996

Copyright © 2011 Rockwell Automation, Inc. All rights reserved. Printed in U.S.A.